

TAPPING SCREWS

Diameter, Head Size & Length Identification

Oval Head Tapping Screws

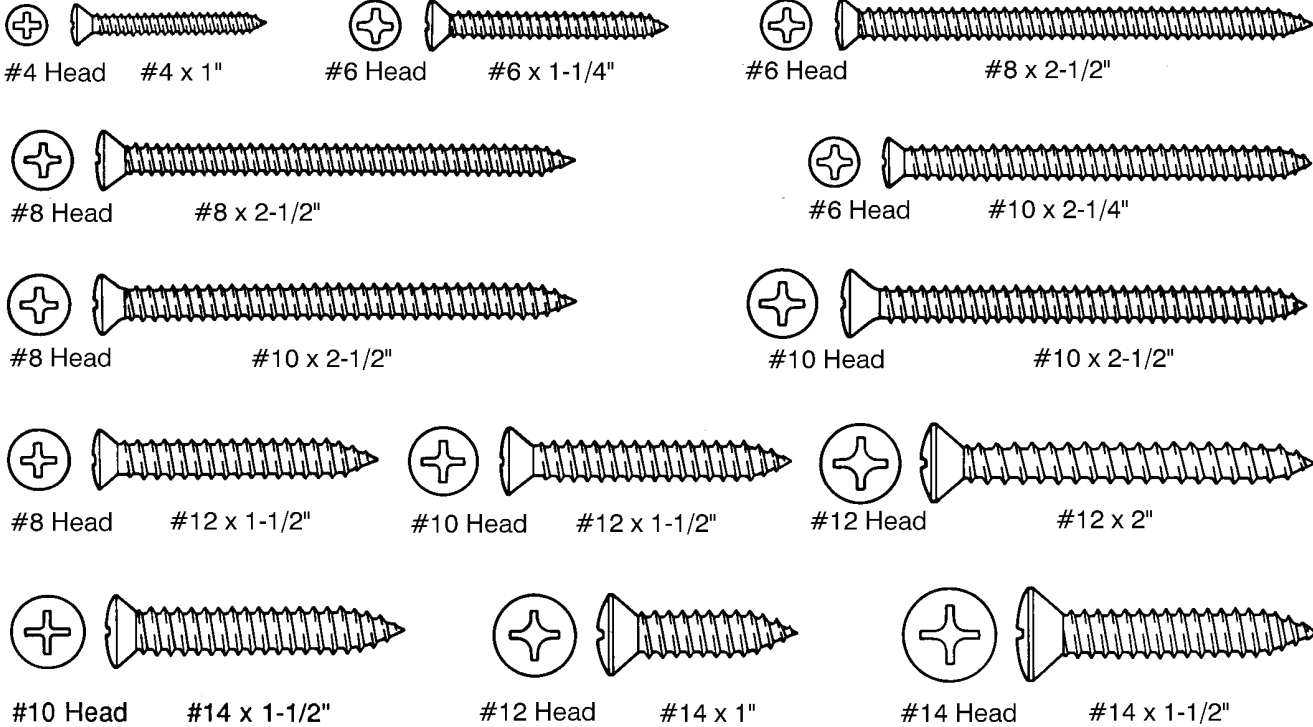

Pan Head Tapping Screws

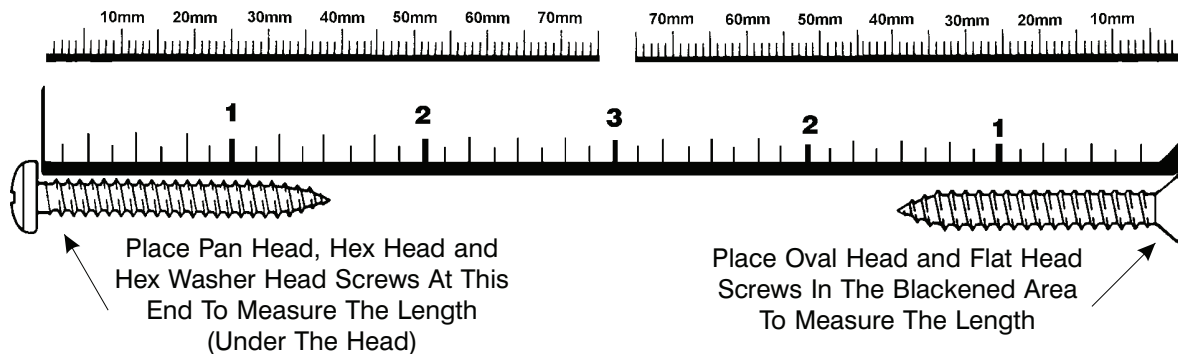
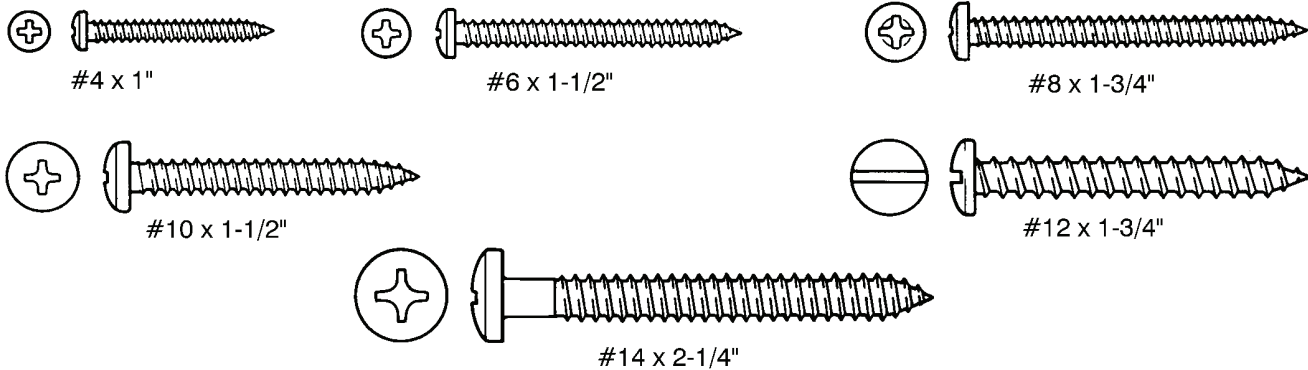

TAPPING SCREWS

Listed According To Size



Phillips Oval Head Tapping Screws

Size	Zinc Part No.	Chrome Part No.	Bk. Oxide Part No.	Unit Pkg.
4 x 3/8"	3062		12893	100
4 x 1/2"	3063	3068	12894	100
4 x 5/8"		5604	12895	100
4 x 3/4"		3069	12896	100
4 x 1"			12897	100
6 x 3/8" 4 Hd		2802		100
6 x 1/2"	2571	2698	12795	100
6 x 5/8"	2699	1793		100
6 x 3/4"	2700	1794	12796	100
6 x 7/8"	2572			100
6 x 1"	2702	1796	12797	100
6 x 1-1/4"	2704	1797	12798	100
8 x 3/8" 6 Hd	2705	2024		100
8 x 3/8"	3484			100
8 x 1/2" 6 Hd	2706	2027	10162	100
8 x 1/2"	2358	2707	10163	100
8 x 5/8" 6 Hd	2708	1421		100
8 x 5/8"	2574	2709		100
8 x 3/4" 6 Hd	1798	1799	10164	100
8 x 3/4"	2359	2710	10165	100
8 x 3/4" 10 Hd		20373		100
8 x 7/8" 6 Hd	1800	2711		100
8 x 7/8"	2575	2712		100
8 x 1" 6 Hd	1801	1483	10166	100
8 x 1"	2360	2713	10167	100
8 x 1-1/8" 6 Hd		1802		100
8 x 1-1/4" 6 Hd	1803	1423	10168	100
8 x 1-1/4"	2361	2716	10169	100
8 x 1-1/2" 6 Hd	2717	1932	10170	100
8 x 1-1/2" 6 Hd		1424		100
(Special Long Shank)				
8 x 1-1/2"	2362	2718	10171	100
8 x 1-3/4" 6 Hd		1933		100
8 x 2" 6 Hd	2632			100
8 x 2"	2633			100
8 x 2-1/2"	3205			100
10 x 1/2" 6 Hd	2720	2656		100
10 x 1/2" 8 Hd		2657		100
10 x 1/2"	2579	2722	11084	100
10 x 5/8" 8 Hd		2724		100
10 x 5/8"	2580			100
10 x 3/4" 6 Hd	2726			100
10 x 3/4" 8 Hd	2727	1717	11087	100
10 x 3/4"	2581	2728	11086	100
10 x 1" 6 Hd	2729	1804		100
10 x 1" 8 Hd	2578	2730	11089	100
10 x 1"	2582	2731	11088	100
10 x 1-1/8" 8 Hd		1807		100
10 x 1-1/4" 8 Hd	2661	2734	11091	100
10 x 1-1/4"	2583	2735	11090	100
10 x 1-1/2" 6 Hd		2046		100
10 x 1-1/2" 8 Hd	2662	20374	11093	100
10 x 1-1/2"	2585		11092	100

Size	Zinc Part No.	Chrome Part No.	Bk. Oxide Part No.	Unit Pkg.
10 x 1-3/4" 8 Hd	2663			100
10 x 1-3/4"	2586			100
10 x 2" 8 Hd	2665			100
10 x 2"	2666			100
10 x 2-1/2"	3207			100
12 x 1/2"	8044			100
12 x 3/4" 10 Hd	8049			100
12 x 3/4"	8050			100
12 x 1"	8056			100
12 x 1-1/2" 10 Hd	8061			100
12 x 1-1/2"	8062			100
12 x 2"	8068			100
14 x 1"	8083			100

For assortments of Phillips Oval Head Tapping Screws, refer to Fix-Kits 6003 and 6501 in the green pages.



Phillips Oval Head Tek[®] Tapping Screws

Phosphate

Auveco Part No.	Size	Unit Pkg.
16736	8 x 1" 6 Hd	50
16737	8 x 1-1/4" 6 Hd	50



Slotted Oval Head Tapping Screws

Bright Zinc Chromate

Auveco Part No.	Size	Unit Pkg.
1432	6 x 1/2"	100
1144	6 x 5/8"	100
1149	8 x 3/4"	100
1137	8 x 1"	100
5616	12 x 5/8"	100
3483	12 x 7/8"	100
5617	14 x 5/8"	100
5618	14 x 2-1/4"	100

Sec. 1

TAPPING SCREWS

Listed According To Size



Pop On Polypropylene Screw Covers & Bases

They're simple to use:

1. Place washer over pilot or starting hole for screw, nail or rivet.
2. Install fastener.
3. Place Snap Cap over washer at slight angle.
4. Simply push Snap Cap down firmly.

Covers



Auveco Part No.	Screw Size	Color	O.D.	Unit Pkg.
13831	#4	Black	1/2"	50
13832	#4	White	1/2"	50
13833	#6	Black	1/2"	50
13834	#6	White	1/2"	50
13835	#8	Black	5/8"	50
13836	#8	White	5/8"	50
13837	#10	Black	5/8"	50
13838	#10	White	5/8"	50

Bases



Auveco Part No.	Screw Size	Use with Cover	Unit Pkg.
13839	#4	13831 & 13832	50
13840	#6	13833 & 13834	50
13841	#8	13835 & 13836	50
13842	#10	13837 & 13838	50



Phillips Flat Head Tapping Screws

Size	Zinc Part No.	Unit Pkg.	Bk. Oxide Part No.	Unit Pkg.
4 x 1/4"	5646	100		
4 x 3/8"	5647	100	12899	100
4 x 1/2"	5648	100	12900	100
4 x 5/8"	5649	100		
4 x 3/4"	5650	100		
6 x 5/16" ...4 Hd.	2736	100		
6 x 1/2" ...4 Hd.	5651	100		
6 x 1/2"	1946	100	12801	100
6 x 5/8"	5653	100		
6 x 3/4" ...4 Hd.	*2803	100		
6 x 3/4"			12802	100
6 x 1"			12803	100
* Chrome				
8 x 3/8" ...6 Hd.	5654	100		
8 x 7/16" ...6 Hd.	1479	100		
8 x 1/2" ...6 Hd.	2804	100	10173	100
8 x 1/2"	5655	100	10172	100
8 x 5/8" ...6 Hd.	5656	100		
8 x 3/4" ...6 Hd.	1712	100	10174	100
8 x 3/4"	2807	100	10175	100
8 x 1" ...6 Hd.	5660	100	10176	100
8 x 1"	5661	100	10177	100
8 x 1-1/4" ...6 Hd.			10178	100
8 x 1-1/4"			10179	100
8 x 1-1/2" ...6 Hd.			12805	50
8 x 1-1/2"			12806	50
10 x 1/2"			12807	100
10 x 3/4"	2810	100	12809	100
10 x 1"	5672	100	12811	50



Metric Torx® Head Tapping Screws

300 Series Stainless Steel

Auveco Part No.	Size	Head Style	Finish	Unit Pkg.
11937	4.2 x 20mm	M7 Oval	Chrome	50
11938	4.2 x 20mm	M7 Oval	Black Ox	50
11944	4.2 x 20mm	M8 Pan	Black Ox	50
14046	4.2 x 25mm	M8 Pan	Black Ox	50
14049	4.2 x 25mm	M8 Pan	Chrome	50
14053	4.2 x 25mm	M7 Oval	Black Ox	50
11945	4.2 x 35mm	M8 Pan	Chrome	25
14047	4.2 x 35mm	M7 Oval	Black Ox	50
14952*	4.2 x 55mm	M8 Pan	Black Ox	50

* Not Fully Threaded



Torx® Insert Bits For Torx® Screws

1" Shank

Auveco Part No.	Bit Size	For Screw Size	Unit Pkg.
12472	T-10	No. 4	1
11949	T-15	No. 6, 8, M4.2	1
11950	T-20	No. 8, M4.2	1
12103	T-25	No. 10	1
14913	T-27	No. 12, 1/4"	1
12104	T-30	1/4"	1
12105	T-40	5/16"	1
14916*	T-55	1/2", 9/16", 5/8"	1

*1-1/4" Shank

Torx® Tools

Torx® Short Arm Key, Power Drive Bits and Hand Drivers are available for installing Torx® Screws. Refer to the "Tools" listing in the Alphabetical Index.

TAPPING SCREWS



Flat Head Torx® Drive Floor Screws

Thread Cutting Screws - Type F
Phosphate & Oil Finish

Auveco Part No.	Size	Drive Size	Unit Pkg.
12098	1/4-20 x 2"	T-30	50
12100	1/4-20 x 2-1/2"	T-30	50



Slotted Pan Head Tapping Screws

Bright Zinc Chromate

Auveco Part No.	Size	Unit Pkg.
3020	4 x 1/4"	100
3022	4 x 1/2"	100
5636	4 x 7/8"	100
3024	4 x 1"	100
1263	6 x 3/8"	100
1452	6 x 1/2"	100
1453	6 x 5/8"	100
1454	6 x 3/4"	100
1455	6 x 1"	100
5639	6 x 1-3/8"	100
1456	8 x 3/8"	100
1146	8 x 1/2"	100
1092	8 x 5/8"	100
1457	8 x 1"	100
3028	8 x 1-1/2"	100
1458	10 x 1/2"	100
1787	10 x 5/8"	100
1265	10 x 3/4"	100
1459	10 x 1"	100
1460	10 x 1-1/2"	100
1266	10 x 1-3/4"	100
5642	12 x 5/8"	100
1344	12 x 3/4"	100
1346	12 x 1"	100
3032	12 x 1-1/2"	100
1347	14 x 1/2"	100
2039	14 x 5/8"	100
1381	14 x 3/4"	100
1382	14 x 1"	100
3036	14 x 1-1/2"	100
3037	14 x 1-3/4"	100
5645	14 x 2-1/4"	100



Phillips Pan Head Tapping Screws

Size	Zinc Part No.	Unit Pkg.	Bk. Oxide Part No.	Unit Pkg.
4 x 1/4"	3071	100	12902	100
4 x 3/8"	3072	100	12903	100
4 x 1/2"	3073	100	12904	100
4 x 5/8"	5619	100		
4 x 3/4"	3074	100	12905	100
4 x 1"	3075	100		
6 x 1/4"	1935	100		
6 x 3/8"	1936	100	16889	100
6 x 1/2"	1937	100	11917	100
6 x 5/8"	5621	100		
6 x 3/4"	2364	100	11918	100
6 x 1"	3076	100	11919	100
6 x 1-1/8"	5623	100		
6 x 1-1/4"	3077	100	11920	100
6 x 1-1/2"	3078	100		
8 x 3/8"	1939	100		
8 x 1/2"	1940	100	10180	100
8 x 5/8"	5625	100		
8 x 3/4"	2365	100	10181	100
8 x 7/8"	5626	100		
8 x 1"	3079	100	10182	100
8 x 1-1/4"	3080	100	10183	100
8 x 1-1/2"	3081	100	12799	50
10 x 3/8"	1942	100		
10 x 1/2"	1943	100	11921	100
10 x 5/8"	2808	100		
10 x 3/4"	2366	100	11922	100
10 x 7/8"	5629	100		
10 x 1"	3082	100	11923	50
10 x 1-1/4"	3083	100	11924	50
10 x 1-1/2"	3084	100	12800	50
12 x 1/2"	3085	100		
12 x 5/8"	5630	100		
12 x 3/4"	2367	100		
12 x 1"	3086	100		
12 x 1-1/4"	3087	100		
12 x 1-1/2"	3088	100		
14 x 1/2"	3089	100		
14 x 5/8"	5632	100		
14 x 3/4"	3090	100		
14 x 7/8"	5633	100		
14 x 1"	3091	100		
14 x 1-1/4"	3092	100		
14 x 1-1/2"	3093	100		
14 x 1-3/4"	3211	100		
14 x 2"	5634	100		
14 x 2-1/4"	2371	50		

For assortments of Phillips Pan Head Tapping Screws refer to Fix Kits 6004 and 6038 in the green pages.

Sec. 1

TAPPING SCREWS

Listed According To Size



Phillips Oval Head Sems® Countersunk Washer Tapping Screws

Size	Chrome Part No.	Unit Pkg.	Bk. Phos Part No.	Unit Pkg.
6 x 5/8"	3537	100	11784	100
6 x 3/4"	3538	100	11785	100
6 x 1"	3539	100	11786	100
8 x 1/2" 6 Hd.			*16930	100
8 x 5/8" 6 Hd.	2771	100	11787	100
8 x 3/4" 6 Hd.	2751	100	11788	100
8 x 1" 6 Hd.	2772	100	11789	100
8 x 1-1/4" 6 Hd.	2773	100	11790	100
8 x 1-1/2" 6 Hd.	14970	50		
10 x 5/8" 8 Hd.	3465	100	14972	100
10 x 3/4" 8 Hd.	3466	100	11791	50
10 x 1" 8 Hd.	3467	100	11792	50
10 x 1-1/4" 8 Hd.	3468	100	14973	50

* Black Oxide Finish



Phillips Oval Head Sems® Flush Washer Tapping Screws

Size	Chrome Part No.	Bk Oxide Part No.	Unit Pkg.
8 x 1/2" 6 Hd.		12956	100
8 x 5/8" 6 Hd.	2774	10652	100
8 x 11/16" 6 Hd.		10653	100
8 x 7/8" 6 Hd.	2775		100
8 x 1" 6 Hd.		12957	100
8 x 1-1/4" 6 Hd.		10654	100



Countersunk



Flush

Phillips Oval Head Sems® Teks® Finishing Screws With No. 6 Head & No. 2 Drill Point

Size	Washer Type	Chrome Part No.	Phos. Part No.	Unit Pkg.
8 x 5/8" Flush		11448	11453	100
8 x 5/8" Ctrsnk		11449	11454	100
8 x 3/4" Flush			20513	100
8 x 3/4" Ctrsnk		11450	11455	100
8 x 1" Ctrsnk		11451	11456	50
8 x 1-1/4" Ctrsnk		11452	11457	50
8 x 1-1/4" Flush			18460	50



Phillips Flat Top Washer Head Tapping Screws Black E-Coat or Zinc

Size	Washer Head O.D.	Zinc Part No.	Black E-Coat Part No.	Unit Pkg.
6 x 1/2" 3/8"			12950	100
6 x 3/4" 3/8"			*12951	100
6 x 1" 3/8"			*12952	100
8 x 1/2" 13/32"		14859	12213	100
8 x 5/8" 13/32"		14860	12214	100
8 x 3/4" 13/32"		14861	12215	100
8 x 1" 13/32"		14862	12216	100
8 x 1-1/4" 13/32"			12217	50
8 x 1-1/2" 13/32"			12218	50
8 x 2" 13/32"			19798	50
10 x 3/4" 15/32"			12953	50
10 x 1" 15/32"			12954	50
10 x 1-1/4" 15/32"			12955	50

*Black Oxide

Black E-Coat Is Excellent For Interior/Exterior Use. 168 Hour Salt Spray



Phillips Pan Head Sems® Tapping Screws Black Phosphate

Auveco Part No.	Size	Washer O.D.	Unit Pkg.
12818	8 x 1/2"	1/2"	50
12820	8 x 3/4"	1/2"	50
12821	8 x 1"	1/2"	50

TAPPING SCREWS

Sec. 1

Listed According To Size



**Slotted Pan Head
Thread Cutting Screws - Type "F"**
Bright Zinc Chromate

Auveco Part No.	Size	Unit Pkg.
5290	8-32 x 1/4"	100
5291	8-32 x 3/8"	100
5292	8-32 x 1/2"	100
5294	8-32 x 3/4"	100
5298	10-24 x 3/8"	100
5301	10-24 x 3/4"	100
5307	1/4-20 x 5/8"	100



**Acorn Indented Hex Washer Head
Tapping Screws
With Phillips Recess**

Auveco Part No.	Size	Hex Size	Washer O.D.	Finish	Unit Pkg.
13736	6 x 1/2"	1/4"	5/16"	Blk Phos.	100
13727	6 x 3/4"	1/4"	5/16"	Zinc	100
13728	6 x 1"	1/4"	5/16"	Zinc	100



Drill Screws
Bright Zinc Chromate
Pinch Point Slotted Hex Washer Head
Tapping Screws

Auveco Part No.	Size	Hex Size	Unit Pkg.
3367	6 x 3/8"	1/4"	100
3374	8 x 1/2"	1/4"	100
3376	8 x 3/4"	1/4"	100

Use Auveco Magnetic Socket Tool No. 7767



Self-Piercing Screws
Zinc

For material thickness up to .060
Use with magnetic chuck 7767

Auveco Part No.	Size	Hex Size	Unit Pkg.
12365	7 x 1/2"	1/4"	100
12367	8 x 5/8"	1/4"	100
12368	8 x 3/4"	1/4"	50
12369	10 x 1/2"	1/4"	50
12370	10 x 3/4"	1/4"	50

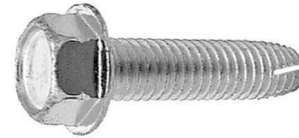

**Hexagon Washer Head
Thread Cutting Screws - Type "F"**
Bright Zinc Chromate

Auveco Part No.	Size	Hex Size	Unit Pkg.
5759	6-32 x 3/8"	1/4"	100
5764	6-32 x 1"	1/4"	100
5766	8-32 x 3/8"	1/4"	100
5767	8-32 x 1/2"	1/4"	100
5768	8-32 x 5/8"	1/4"	100
5769	8-32 x 3/4"	1/4"	100
5773	10-24 x 3/8"	5/16"	100
5774	10-24 x 1/2"	5/16"	100
5775	10-24 x 5/8"	5/16"	100
5776	10-24 x 3/4"	5/16"	100
5778	10-24 x 1"	5/16"	100
8437	12-24 x 1/2"	5/16"	100
8438	12-24 x 3/4"	5/16"	100
8439	12-24 x 1"	5/16"	100
5781	1/4-20 x 3/8"	3/8"	100
5782	1/4-20 x 1/2"	3/8"	100
5783	1/4-20 x 5/8"	3/8"	100
5784	1/4-20 x 3/4"	3/8"	100
5786	1/4-20 x 1"	3/8"	100
5787	1/4-20 x 1-1/4"	3/8"	100
8441	5/16-18 x 1/2"	1/2"	100
8442	5/16-18 x 3/4"	1/2"	100
8443	5/16-18 x 1"	1/2"	100
8444	5/16-18 x 1-1/4"	1/2"	100
15355	5/16-18 x 1-1/2"	1/2"	50
15356	5/16-18 x 1-3/4"	1/2"	50
11294	3/8-16 x 3/4"	9/16"	50
11295	3/8-16 x 1"	9/16"	50
11296	3/8-16 x 1-1/4"	9/16"	25
11297	3/8-16 x 1-1/2"	9/16"	25
15357	3/8-16 x 1-3/4"	9/16"	25
15358	3/8-16 x 2"	9/16"	25

TRI-LOBULAR "TT" SCREWS



Thread Cutting • Grade 5 • Zinc Plated

Auveco Part No.	Size	Unit Pkg.
-----------------	------	-----------

Phillips Pan Head

16491	8-32 x 3/4"	100
-------	-------------	-----

Sec. 1

TAPPING SCREWS

Listed According To Size



Teks® Self-Drilling Self-Tapping Screws



Indented Hex Head Tapping Screws Bright Zinc Chromate

Size	Hex Size	Zinc Part No.	Unit Pkg.	Bk. Oxide Part No.	Unit Pkg.
------	----------	---------------	-----------	--------------------	-----------

Auveco Part No.	Size	Hex Size	Unit Pkg.
-----------------	------	----------	-----------

Phillips Pan Head

#2 Teks® Point					
8 x 7/16"		9604	100		
8 x 1/2"		9605	100	16033	100
8 x 3/4"		9606	100	16034	100
8 x 1"		11904	100	16035	50
10 x 1/2"		9607	100	16036	50
10 x 3/4"		9608	100	16037	50
10 x 1"		9609	100	16038	50
12 x 1"		11905	50		

2389	8 x 1/2"	1/4"	100
5676	8 x 5/8"	1/4"	100
2485	8 x 3/4"	1/4"	100
2486	8 x 1"	1/4"	100
3212	8 x 1-1/4"	1/4"	100

Hex Washer Head

#2 Teks® Point					
8 x 7/16"	1/4"	9610	100		
8 x 1/2"	1/4"	9611	100	16039	100
8 x 3/4"	1/4"	9612	100	16040	100
8 x 1"	1/4"	11906	100	16041	50
8 x 1-1/4"	1/4"	11907	50		
8 x 1-1/2"	1/4"	11908	50		
10 x 1/2"	5/16"	9613	100	16042	50
10 x 5/8"	5/16"	9614	100		
10 x 3/4"	5/16"	9615	100	16043	50
10 x 1"	5/16"	9616	100	16044	50

8011	10 x 1/2"	5/16"	100
2487	10 x 3/4"	5/16"	100
3214	10 x 1-1/4"	5/16"	100
3215	10 x 1-1/2"	5/16"	100

1780	12 x 1/2"	5/16"	100
2107	12 x 3/4"	5/16"	100
3216	12 x 1"	5/16"	100
3217	12 x 1-1/4"	5/16"	100

Super Teks® - Hex Washer Head

#3 Teks® Point					
10 x 1-1/4"	5/16"	11909	50		
10 x 1-1/2"	5/16"	11910	50		
12 x 3/4"	5/16"	9617	100		
12 x 1"	5/16"	11911	25		
12 x 1-1/4"	5/16"	11912	25		
12 x 1-1/2"	5/16"	11913	25		
14 x 3/4"	3/8"	9620	100		
14 x 1"	3/8"	11914	25		
14 x 1-1/4"	3/8"	11915	25		
14 x 1-1/2"	3/8"	11916	25		

2012	14 x 1/2"	3/8"	100
2391	14 x 5/8"	3/8"	100
1781	14 x 3/4"	3/8"	100
2109	14 x 3/4"	7/16"	100
2266	14 x 1"	7/16"	100
2267	14 x 1-1/4"	7/16"	100
3219	14 x 1-1/2"	7/16"	100
5685	14 x 2"	7/16"	100

2110	5/16 x 3/4"	1/2"	100
2268	5/16 x 1"	1/2"	100
2269	5/16 x 1-1/4"	1/2"	100
3220	5/16 x 1-1/2"	1/2"	100

5329	3/8 x 3/4"	9/16"	50
5330	3/8 x 1"	9/16"	50
5331	3/8 x 1-1/4"	9/16"	50
5332	3/8 x 1-1/2"	9/16"	50

Teks® Point Material Thickness		
Screw Size	#2 Point	#3 Point
#8	.035" - .100"	.100" - .140"
#10	.035" - .110"	.110" - .175"
#12	.035" - .140"	.110" - .210"
#14	.035" - .175"	.110" - .210"

Phillips Oval Head Teks® Tapping Screws

Phosphate

Auveco Part No.	Size	Unit Pkg.
-----------------	------	-----------

16736	8 x 1"	.6 Hd	50
16737	8 x 1-1/4"	.6 Hd	50

For an assortment of Teks® Tapping Screws see Fix-Kit No. 6144 in the green pages.

TAPPING SCREWS

Listed According To Size



Hexagon Washer Head Tapping Screws
(Washer Attached Solid To Head)

Size	Hex Size	Zinc Part No.	Unit Pkg.	Bk Oxide Part No.	Unit Pkg.
10 x 1/2"	5/16"	2369	100	16149	100
10 x 5/8"	5/16"	2809	100		
12 x 5/8"	5/16"	2967	100		
12 x 3/4"	5/16"	2968	100		
12 x 1"	5/16"	2969	100		
14 x 1/2"	3/8"	9825	100		
14 x 5/8"	3/8"	2370	100		
14 x 3/4"	3/8"	2330	100	16152	100
14 x 3/4"	7/16"	2973	100		
14 x 1"	3/8"	2974	100		
14 x 1-1/2"	3/8"	2976	100		
5/16 x 3/4"	7/16"	2978	100		
5/16 x 1"	7/16"	2979	100		
5/16 x 1-1/4"	7/16"	2980	100		
5/16 x 1-1/2"	7/16"	2981	100		



Hexagon Head Sems® Tapping Screws
(Washer Loose From Head)

Bright Zinc Chromate

Auveco Part No.	Size	Hex Size	Washer O.D.	Unit Pkg.
2983	12 x 3/4"	7/16"	5/8"	100
2604	14 x 3/4"	3/8"	5/8"	100
2988	14 x 3/4"	7/16"	21/32"	100
2605	14 x 1"	3/8"	21/32"	100
2989	14 x 1"	7/16"	21/32"	100
2991	14 x 1-1/2"	7/16"	21/32"	100
2994	5/16 x 1"	7/16"	11/16"	100
2996	5/16 x 1-1/2"	7/16"	11/16"	100



Slotted Hexagon Head Tapping Screws

Bright Zinc Chromate

Auveco Part No.	Size	Hex Size	Unit Pkg.
3342	6 x 3/4"	1/4"	100
3350	8 x 1"	1/4"	100
3352	10 x 3/8"	5/16"	100



Slotted Hexagon Washer Head Tapping Screws

Bright Zinc Chromate

Auveco Part No.	Size	Hex Size	Unit Pkg.
3367	6 x 3/8"	1/4"	100
3368	6 x 1/2"	1/4"	100
3369	6 x 5/8"	1/4"	100
3373	8 x 3/8"	1/4"	100
3374	8 x 1/2"	1/4"	100
3375	8 x 5/8"	1/4"	100
3376	8 x 3/4"	1/4"	100
3378	8 x 1"	1/4"	100
3379	8 x 1-1/4"	1/4"	100
3380	10 x 3/8"	5/16"	100
3381	10 x 1/2"	5/16"	100
3382	10 x 5/8"	5/16"	100
3383	10 x 3/4"	5/16"	100
3385	10 x 1"	5/16"	100
3386	10 x 1-1/4"	5/16"	100
3387	10 x 1-1/2"	5/16"	100
3388	12 x 1/2"	5/16"	100
3389	12 x 5/8"	5/16"	100
3390	12 x 3/4"	5/16"	100
3392	12 x 1"	5/16"	100
3393	12 x 1-1/4"	5/16"	100
3394	12 x 1-1/2"	5/16"	100



Hex Head Lag Screws
Zinc Plated

Auveco Part No.	Size	Hex Size	Unit Pkg.
9091	5/16 x 2-1/2"	1/2"	50
9100	3/8 x 4"	9/16"	25